



INDUSTRIES SERVED



CHOCOLATE & CANDY



MEAT & POULTRY



DRESSINGS, RELISHES & DIPS



SOUPS & SAUCES



CHEESE & DAIRY



PET FOOD



SAVOURY & PIE FILLINGS



READY MEALS

The UDK is a compact hygiene station and is designed to ensure that employees or visitors correctly sanitizer their hands and disinfect the soles of there footwear prior to entering the food production or processing areas.

The machine is fitted with a stainless steel turnstile to ensuring operators use the machine correctly and have thoroughly sanitized their hands and footwear.

FEATURES

304
 STAINLESS STEEL

+
 HAND SANITIZE

+
 SOLE SANITIZE

TURNSTILE ACCESS

ADJUSTABLE TIMES

MAINS OPERATED

SENSOR OPERATED

CHEMICAL AUTO DOSING

CHEMICAL STORAGE

A B
 CUSTOM CARRIAGE

HYGIENIC BY DESIGN

SINGLE LANE

UDK SINGLE LANE HAND SANITATION AND SOLE SANITIZER HYGIENE STATION



OPERATIONAL DESIGN

As the operator steps on to the machine an electrical sensor initiates the rotation of brushes and light illuminates the inside chamber to initiate hand sanitize. Insertion of both hands into the chamber activates the sanitizer spray. Whilst sanitizing hands, the foot sanitation basin, full of sanitation solution sanitizes the bottoms of footwear.

Once the hand sanitation cycle is complete the turnstile unlocks allowing the operator to pass through into the production area. On leaving the production area the operator steps onto the machine, a sensor detects their presence unlocking the turnstile allowing them to pass through.

YOUR CHOICE

Unlike some of our competitors CM Process Solutions warranty does not obligate you to buy chemicals from us in order to receive spare parts or support.

We understand that each application is unique, and we fully believe that there is no one who understands your needs better than you, the customer and your current chemical supplier.



sales@cmpsolutions.net
t. 951 808 4376 f. 951 808 8657

[View this product online](#)

FEATURES

The UDK range is fully 304 grade stainless steel with sandblasted finish. The machine automatically doses the correct amount of hand and footwear sanitation chemicals.

All process parameters are controlled digitally to be uniquely correct for your production system.

SANITARY DESIGN

As with all our equipment the range of hygiene stations are built using hygienic principles. The construction of the machine is manufactured from 304 grade stainless steel, surfaces are radiused, so excess liquid drains easily from the frame. Chemical is stored within the compartment of the machine.

MACHINE SERVICE DETAILS

| | |
|-----------------|---|
| ELECTRIC | 110 v 60 HZ single phase 4 wire supply 24 v AC control circuit. |
| WATER | 1 x ¾" NPT Inlet. 43 -65 psi inlet pressure (warm if available). |
| DRAIN | 1 x 2 " Outlet Gravity only. |

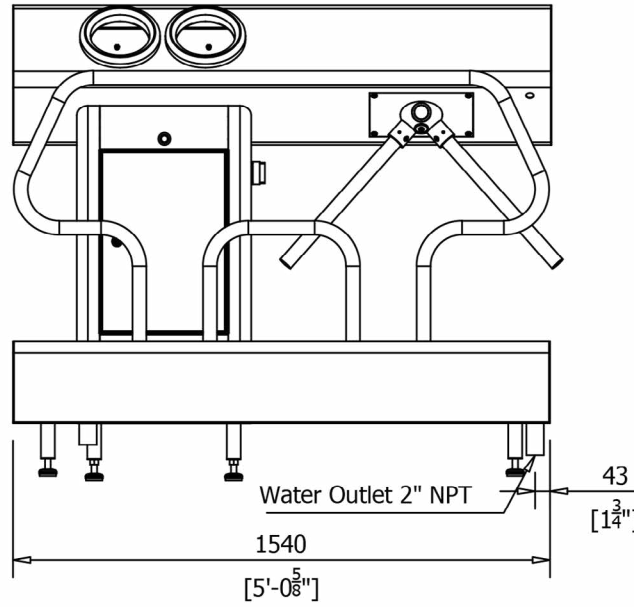

El.Connection 480V, 3~, 60Hz, 16A Max. Fuse

Water Inlet 3/4" NPT

Water Outlet 2" NPT

